

## Analysis of Energy Loss of Distribution Network of PT. PLN (Persero) ULP Banda Aceh

Fauzia Haz<sup>1,\*</sup>, Andi Ahmad Fauzan Anshar<sup>2</sup>, Giri Angga Setia<sup>3</sup>, Naftalin Winanti<sup>4</sup> & Ahmad Daelami<sup>5</sup>

<sup>1,2,3,4,5</sup> Program Studi Teknik Elektronika, Universitas Jendral Achmad Yani, Jl. Terusan Jendral Sudirman, Cimahi, Indonesia  
[fauzia.haz@lecture.unjani.ac.id](mailto:fauzia.haz@lecture.unjani.ac.id)<sup>1</sup>, [ahmad.andi@pln.co.id](mailto:ahmad.andi@pln.co.id)<sup>2</sup>, [giri.anggasetia@lecture.unjani.ac.id](mailto:giri.anggasetia@lecture.unjani.ac.id)<sup>3</sup>,  
[naftalin.winanti@lectureunjani.ac.id](mailto:naftalin.winanti@lectureunjani.ac.id)<sup>4</sup>, [ahmad.daelami@lecture.unjani.ac.id](mailto:ahmad.daelami@lecture.unjani.ac.id)<sup>5</sup>



**Abstract**— The aim of this research to identify areas requiring further attention to enhance electricity distribution efficiency. Data collection is conducted through observation and documentation methods to obtain secondary data such as Single Line Diagram, Distribution Transformer Load Current, Substation Voltage, Conductor Type, Conductor Length, and Conductor Cross-Sectional Area. Secondary data is processed and analyzed to obtain the conductor resistance value, conductor/line power losses, transformer power losses, total power losses, and total energi losses occurring in the distribution network using mathematical calculations, followed by simulation using the ETAP (Electrical Transient Analysis Program) application. After manually calculating power losses in the PT. PLN (Persero) ULP Banda distribution network at Penyulang Nusantara, which reached 7.84034 kW, the simulation results using the ETAP software show 7.8 kW, with a power loss percentage of 0.69% relative to the load. Following the simulation of improvement efforts using ETAP (conductor uprating and load balancing), power losses decrease to 4.4 kW (a reduction of 3.4 kW), with a percentage of 0.39%. The energi losses before improvement are 5,645.045 kWh (1.802%), and after improvement, it becomes 3,168 kWh (a reduction of 2,477 kWh) with a percentage of 1.59%. The improvement efforts result in savings of IDR 3,578,586.91.

**Keywords**— conductor uprating; distribution network; efficiency; energi losses; load balancing

### I. Introduction

Electrical energy is one of the main needs, this is because electrical energy is easy to transport and convert into other forms of energy [1]. PT. PLN (Persero), as a State-Owned Enterprise operating in the electricity industry, it has the responsibility to provide excellent service [2].

The increasing growth in electrical energy demand in recent years is in line with the development of various industrial sectors and population growth [3]. Therefore PT. PLN (Persero) as a company providing electricity services in Indonesia, especially in the Banda Customer Service Unit (ULP), has a big responsibility to ensure reliable and efficient electricity distribution to customers in its area. One important aspect in ensuring the quality of electricity distribution is the analysis of power and energy losses in the distribution network[4].

Energy loss in the electricity system is a loss of energy that cannot be utilized, so this is a form of energy waste and reduces efficiency. [5]. High power and energy losses can result in economic and operational losses for companies and have a negative impact on electricity availability for customers [6]. This energy loss needs to be considered and analyzed so that it does not cause significant losses for PT. PLN (Persero).

PT. PLN (Persero) ULP Banda is a customer service unit under PT. PLN (Persero) Main Unit for the Maluku and North Maluku Regions which is tasked with providing electric power serving the Banda District, Central Maluku Regency, Maluku Province with a total energy production of 8,241,550 kWh during 2023 until September, as well as a total peak load of 8,241,550 kWh. carried by 2.1 MW. The electricity distribution system at ULP Banda consists of four feeders which are supplied from Diesel Power Plants (PLTD) which are spread across five small islands in Banda District. PT PLN (Persero) ULP Banda's distribution loss achievement in September 2023 is 8.24%. This figure has increased from the previous month, namely 5.89% in August 2023 (up 2.35% from the previous month), and also experienced an increase from the achievement in September 2022, namely 6.54% (up 1.7% from previous year)[7].

This increase requires special attention, because the achievement of this loss percentage is still far above the target based on the Management Contract set by PT. PLN (Persero) Main Unit for Maluku and North Maluku Region, namely 7.41%. Therefore, power and energy loss analysis is needed, so that PT. PLN (Persero) ULP Banda can identify areas that require further attention to improve electricity distribution efficiency. Therefore, the aim of this research is to analyze the energy losses of PT's distribution network. PLN (Persero) ULP Banda.

## II. Research Methodology

### A. Method

This research is a qualitative research with the aim of analyzing energy losses in the distribution network of PT PLN (Persero) ULP Banda.

### B. Data collection technique

The information in this research was collected using several techniques including literature study, observation, documentation and interviews. Literature studies are carried out by investigating reference sources, including books, journals, websites, as well as notes or documents relevant to the theme, especially those published by PT. PLN (Persero)[8]. Observations were carried out by making direct observations in the field, namely PT. PLN (Persero) Banda Customer Service Unit. The data collected is Single Line Diagram, Loading Current for Each Transformer (IR, IS, IT), Feeder Voltage, Feeder Length, Type of Conductor, Cross-sectional Area of the Conductor, as well as other supporting information.

The analysis information technique used is by describing or describing the data that has been collected. In this

research, feeder technical data was collected, the data was then processed by calculating losses that occurred in PT's distribution network. PLN (Persero) ULP Banda Nusantara feeder using mathematical calculation formulas. Next, carry out a simulation of the loss calculation that occurs in the PT distribution network. PLN (Persero) ULP Banda uses ETAP 19.0.1 software. The results of mathematical calculations and simulations in ETAP 19.0.1 software are reviewed to ensure that the calculations and simulations that have been carried out are in accordance with applicable standards.

## III. Result and Conclusion

### A. Power Loss Calculation

Calculation of power losses in distribution lines begins by calculating the current in each transformer. Calculation of the current in each transformer uses the following equation formula:

$$S = \sqrt{3} V I \tag{1}$$

The following are the results of calculating the current transformer:

Table 1. Transformer Current Calculation Results

SUBSTATION	CAPACITY (kVA)	CURRENT (A)			LOAD (VA)	Itrafo
		R	S	T		
BNDNST001	100	27,90	32,27	102,60	35809,40	1,03
BNDNST002	25	12,74	17,86	12,75	9537,00	0,28
BNDNST003	25	14,23	12,64	9,63	8030,00	0,23
BNDNST004	200	74,80	85,11	74,80	51636,20	1,49
BNDNST005	50	0,07	0,08	0,30	98,12	0,00
BNDNST006	50	30,05	32,75	27,35	19833,00	0,57
BNDNST007	50	29,90	11,69	20,40	13637,80	0,39
BNDNST008	250	6,90	33,16	0,09	8833,00	0,25
BNDNST009	160	11,15	14,05	7,67	7231,40	0,21
BNDNST010	50	42,09	8,77	12,28	13890,80	0,40
BNDNST011	50	44,45	56,50	50,78	33380,60	0,96
BNDNST012	100	17,57	12,99	16,50	10353,20	0,30
BNDNST013	250	77,30	92,30	74,40	53680,00	1,55

BNDNST014	100	20,20	27,95	3,98	11468,60	0,33
BNDNST015	50	36,94	32,78	29,94	21925,20	0,63
BNDNST016	50	25,36	8,73	19,36	11759,00	0,34
BNDNST017	200	205,50	209,00	186,80	132286,00	3,82

Next, determine the load current on each cable/conductor based on the single line diagram image below diagram di bawah ini[9].

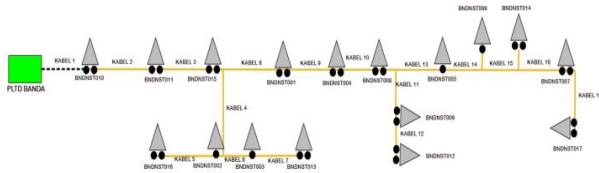

Figure 1. Distribution of Nusantara Feeder Channel Cables

Based on the single line diagram image, the current in each conductor is obtained which is outlined in the following table.

Table 2. Load Current Calculation Results

WIRE	INFORMATION	CURRENT (A)
KABEL 1	KABEL 2+BNDNST010	12,80
KABEL 2	KABEL 3+BNDNST011	12,40
KABEL 3	KABEL 4+KABEL 8+BNDNST015	11,44
KABEL 4	KABEL 5+KABEL 6+BNDNST002	2,40
KABEL 5	BNDNST016	0,34
KABEL 6	KABEL 7+BNDNST003	1,78
KABEL 7	BNDNST013	1,55
KABEL 8	KABEL 9 +BNDNST001	8,41
KABEL 9	KABEL 10+BNDNST004	7,37
KABEL 10	KABEL 11+BNDNST008	5,88
KABEL 11	KABEL 12+KABEL 13+BNDNST009	5,63
KABEL 12	BNDNST012	0,30
KABEL 13	KABEL 14+BNDNST005	5,12

KABEL 14	KABEL 15+BNDNST006	5,12
KABEL 15	KABEL 16+BNDNST014	4,54
KABEL 16	KABEL 17+BNDNST007	4,21
KABEL 17	BNDNST017	3,82

The next step is to calculate the conductor resistance at the Indonesian feeder. Data obtained from PT. PLN (Persero) ULP Banda, the length of the conductor on the Nusantara feeder is 10,685 kms or 10,685 m consisting of two types of conductor construction, namely Medium Voltage Overhead Lines (SUTM) which consist of the AAAC type with a cross-sectional area of 70 mm<sup>2</sup> and Medium Voltage Ground Cable Lines (SKTM) XLPE type with a cross-sectional area of 150 mm<sup>2</sup>, with a conductor resistance value for aluminum of 0.036Ωmm<sup>2</sup>/m.[6]

The results of the calculation of the total loss of the Indonesian feeder channel in this study show that the results of the calculation of the total loss of the channel power at PT. PLN (Persero) ULP Banda Nusantara feeder is 622.99 Watt.

The next step is to calculate the distribution transformer power losses. The power loss that occurs in a transformer is the accumulation of power loss/loss in the iron core and power loss/loss in the copper winding. Power losses in iron cores are usually constant, almost unaffected by additional load. The research results show that the total iron losses that occur in each transformer at PT. PLN (Persero) ULP Banda Penyulang Nusantara is 4,660 Watts. Meanwhile, copper shrinkage/loss in the transformer is caused by the load current flowing in the transformer copper windings. The research results show that iron losses occur in each transformer at PT. PLN (Persero) ULP Banda Penyulang Nusantara is 4,660 Watts.

Based on the results of calculating the total copper loss and iron loss on each transformer, we can calculate the total loss that occurs on each transformer using the equation formula:

$$\begin{aligned}
 P_{trans} &= P_{fe} + P_{cu} & (2) \\
 P_{trans} &= 4660 + 2557,35 \\
 P_{trans} &= 7217,35 \text{ Watt}
 \end{aligned}$$

So that the total transformer loss at PT is obtained. PLN (Persero) ULP Banda Penyulang Nusantara is 7,217.35 Watt.

To find out the total power losses that occur, you need to add up the total channel losses with the total transformer losses that have been calculated previously. The total sum of the power losses that occur is as follows.

$$\begin{aligned}
 P_{total} &= P_{wire} + P_{trans} & (3) \\
 P_{total} &= 7217,35 + 622,99 \\
 P_{total} &= 7840,34 \text{ Watt} \\
 P_{total} &= 7,84034 \text{ kW}
 \end{aligned}$$

So, from the calculation above it is obtained that the total power loss that occurs at PT. PLN (Persero) ULP Banda at the Nusantara Feeder is 7.840.34 Watts or 7.84034 kW.

Power loss calculations can be done using ETAP 19.0.1 simulation. The first step in calculating power losses using the ETAP 19.0.1 simulation is to create a single line diagram. The following is a single line

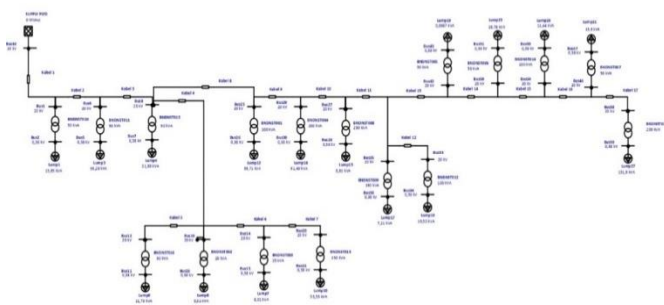

Figure 2. Results of Single Line Diagram Series in ETAP Software

After the single line diagram is created, the next step is to enter the technical data that has been obtained for each component. Then run the ETAP software, then open the Report Manager menu and select Losses on the Summary tab, then the results of the calculation of

power losses or losses will appear. Based on the ETAP 19.0.1 simulation results, it shows that the total power loss that occurred at the Nusantara Feeder PT. PLN (Persero) ULP Banda is 7.8 kW. This result is not much different from the results obtained through manual mathematical calculations of power losses, namely 7.84034 kW.

Apart from calculating power loss, researchers also calculated the percentage of power loss. Before calculating the percentage of power loss, start by determining the total power of the Nusantara feeder load. The calculation results of the Total Load Power on the Nusantara Feeder are 1.126.188.72 Watt.

Next, the percentage of power loss that occurs is calculated using the equation formula.

$$\begin{aligned}
 \%P_{loss} &= (7.840,34) / (1.126.188,72) \times 100\% & (4) \\
 \%P_{loss} &= 0,69\%
 \end{aligned}$$

So, based on the calculations above, it can be seen that the percentage of power loss at the Nusantara Feeder is 0.69%.

*B. Perhitungan Susut Energi*

To calculate the total energy losses at the Nusantara Feeder, use the following equation formula with a time span of one month (30 days).

$$\begin{aligned}
 \Delta E &= 7,84034 \text{ kW} \times 24 \text{ Hours} \times 30 \text{ Days} & (5) \\
 \Delta E &= 5.645,045 \text{ kWh}
 \end{aligned}$$

The total energy losses that occur at PT. PLN (Persero) ULP Banda, especially in Penyulang Nusantara within a period of one month (30 days) was 5.645.045 kWh.

Meanwhile, to calculate the percentage of energy loss based on the use of kWh of energy sent using an equation formula where the energy sent is used using the results of the feeder kWh meter readings for November 2023.

$$\%Power Loss (\Delta E) = \frac{5645,045}{313200} \times 100\% \quad (6)$$

$$\%Power Loss(\Delta E) = 1,802\%$$

So, the percentage of energy losses that occur at PT. PLN (Persero) ULP Banda, especially in Penyulang Nusantara within a period of one month (30 days) was 1.802%.

*C. Calculation of losses borne by PLN*

In order to calculate the rupiah value of this energy loss, the assumption of the electricity price per kWh in the R-1/TR 1300 VA power bill group is used based on the October-December 2023 Electricity Tariff (Rp. 1,444.70/kWh).

$$Total Loss = Total Power Loss \times TTL \quad (7)$$

$$Total Loss = 5.645,045 \text{ kWh} \times Rp.1.444,70/\text{kWh}$$

$$Total Loss = Rp 8.155.396,51$$

Based on the calculation of the total losses borne by PT. PLN (Persero) ULP Banda due to losses that occurred in the Primary Distribution Network at Nusantara Feeders within a period of 30 days amounted to Rp. 8,155,396.51. Results of reporting losses in ETAP software after repair efforts at Feeder Nusantara PT. PLN (Persero) ULP Banda is 4.4 kW.

Next, the power loss percentage is calculated based on the ETAP 19.0.1 simulation results after improvement efforts have been made using the following equation formula:

$$\%Power Loss=(4,4)/(1.126,18872) \times 100\% \quad (8)$$

$$\%Power Loss=0,39\%$$

So, based on the calculations above, it can be seen that the percentage of power loss at the Nusantara Feeder after repair efforts is carried out is 0.39%.

To calculate the total energy losses at the Nusantara Feeder, use an equation formula with a time span of one month (30 days).

$$\Delta E = 4,4 \text{ kW} \times 24 \text{ Hours} \times 30 \text{ Days} \quad (9)$$

$$\Delta E = 3168 \text{ kWh}$$

So, the total energy losses that occur at PT. PLN (Persero) ULP Banda, especially in Penyulang Nusantara, within a period of one month (30 days) after the repair steps were carried out was 3,168 kWh.

Meanwhile, to calculate the percentage of energy loss based on the use of kWh of energy sent, we use an equation formula where for the energy sent, we use the results of the feeder kWh meter readings for November 2023 [10]. The calculation results show the percentage of energy losses that occur at PT. PLN (Persero) ULP Banda, especially in Penyulang Nusantara, within one month (30 days) after the corrective steps were taken was 1.59%.

The next step is to save energy in kWh after simulating repair steps using ETAP 19.0.1 software :

$$\text{kWh Saving} = \text{Before} - \text{After Repair} \quad (10)$$

$$\text{kWh Saving} = 5645,045 - 3168$$

$$\text{kWh Saving} = 2477,045 \text{ kWh}$$

In order to calculate the rupiah value of the amount of energy that can be saved, an assumption of the electricity price per kWh in the R-1/TR 1300 VA power tariff group based on the October-December 2023 Electricity payment is used. (Rp. 1,444.70/kWh)

$$\text{Rupiah Saving} = \text{Power loss Total} \times TTL \quad (11)$$

$$\text{Rupiah Saving} = 2477,045 \text{ kWh} \times Rp.1.444,70/\text{kWh}$$

$$\text{Rupiah Saving} = Rp.3.578.586,91$$

Based on the calculations above, the savings that can be achieved by PT. PLN (Persero) ULP Banda after efforts to repair losses using ETAP 19.0.1 software simulation that occurred in the Primary Distribution Network at Nusantara Feeders within a period of 30 days amounted to Rp. 3,578,586.91.

*D. Discussion*

The length on all of the main line in Penyulang Nusantara reaches 10,685 kms, and serves 17 distribution transformers. After carrying out mathematical calculations of power losses manually, both line power losses and transformer power losses, the total power losses in the PT distribution network. PLN (Persero) ULP Bandapada Penyulang Nusantara before the repair efforts were carried out produced 7.84034 kW. Meanwhile, based on simulation results in ETAP 19.0.1 software, it is 7.8 kW. The percentage of power loss to load power reaches 0.69%.

Next, a simulation of repair efforts in the form of conductor uprating and load balancing was carried out using ETAP 19.0.1 software, to obtain the total power losses in the PT distribution network. PLN (Persero) ULP Banda at the Nusantara Feeder is 4.4 kW, with a percentage of power loss to load power of 0.39%. For more details, see the following table and graph :

Table 3. Power Loss Compare

condition	Power Loss	
	kW	%
Before Repair	7,8	0,69
After Repair	4,4	0,39
Reducing Technical Losses	3,4	0,3

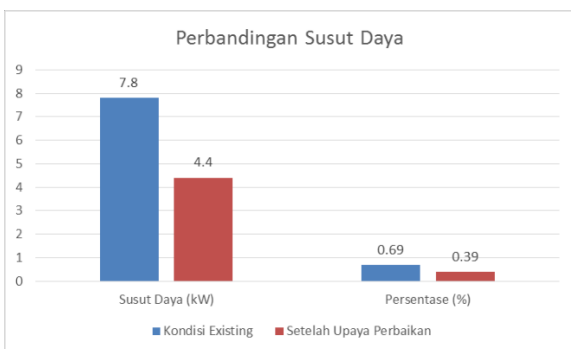

Figure 3. Power Loss Comparison Chart

Based on the table 3 and graph on the figure 3 above, it can be seen that after carrying out improvements in the form of conductor uprating and load balancing, power loss decreased from 7.8 kW to 4.4 kW (a decrease of 3.4 kW), and the percentage of power loss decreased from 0.69 % to 0.39%.

As for energy losses, the total energy losses in the PT distribution network were obtained. PLN (Persero) ULP Banda at the Nusantara Feeder before it was carried out amounted to 5,645,045 kWh, with an energy loss percentage of 1.802%. This means that around 1.802% of the energy distributed by Penyulang Nusantara is not counted as kWh income. From this incalculable energy, PT. PLN (Persero) ULP Banda suffered a loss of Rp. 8,155,396.51 in a 30 day period.

Table 4. Energy Loss Compare

condition	Energy Loss	
	kWh	%
Before Repair	7,8	0,69
After Repair	4,4	0,39
Reducing Technical Losses	3,4	0,3

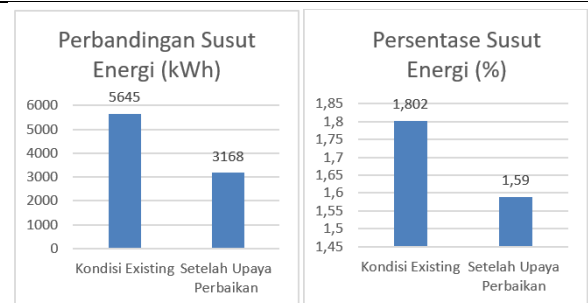

Figure 4. Energy Loss Comparison Chart

The graph on the Figure 4 and table 4 above shows that after improvements were made in the form of conductor uprating and load balancing, energy losses decreased from 5,645 kWh to 3,168 kWh (a decrease of 2,477 kWh), and the percentage of energy losses decreased from 1.802% to 1.59%. Thus, the savings that PT. PLN (Persero) ULP Banda after efforts to repair losses using ETAP 19.0.1 software simulation that occurred in the Primary Distribution Network at Nusantara Feeders within a period of 30 days amounted to Rp. 3,578,586.91.

#### IV. Conclusion

Based on the description of the results and discussion, it can be concluded that:

1. The amount on all of power loss at PT. PLN (Persero) ULP Banda at Penyulang Nusantara is 7.84034 kW, with a percentage of 0.69% of the total load power, namely 1,126,188.72 Watts. The total value of energy losses is 5,645,045 kWh, with a percentage of 1.802%.
2. The amount of loss borne by PT. PLN (Persero) ULP Banda due to losses that occurred in the Primary Distribution Network at Nusantara Feeders within a period of 30 days amounted to Rp. 8,155,396.51.
3. The Efforts that can be made to minimize energy losses in the PT distribution network. PLN (Persero) ULP Banda carried out conductor uprating and load balancing. From these efforts, through simulations in ETAP 19.0.1 software, a reduction in power loss was obtained from 7.8 kW to 4.4 kW (a decrease of 3.4 kW) with a decrease in the percentage of power loss from 0.69% to 0.39% . There was also a decrease in energy losses from 5,645,045 kWh to 3,168 kWh (a decrease of 2,477 kWh) with a decrease in the percentage of energy losses from 1.802% to 1.59%. Thus, the savings that PT. PLN (Persero) ULP Banda after efforts to repair losses using ETAP 19.0.1 software simulation that occurred in the Primary

Distribution Network at the Nusantara Feeder within a period of 30 days amounted to Rp. 3,578,586.91.

#### Referensi

- [1] D. A. S and E. Ervianto, "Dengan Pendekatan Kurva Beban Pada Jaringan Distribusi Pt . Pln ( Persero ) Area Pekanbaru," *Jurnal Teknik Elektro*, vol. 3, no. 2, p. 6, 2016.
- [2] Z. Syamsudin and H. Suyanto, "Analisis Susut Energi Pada Tegangan Rendah Di Wilayah Pt. Pln (Persero) Area Bulungan," *Jurnal Siset*, vol. 5, no. 2, pp. 51–61, 2015.
- [3] R. C. D. Sarikin, "ANALISIS SUSUT DAYA DAN ENERGI PADA JARINGAN DISTRIBUSI DI PT. PLN (Persero) RAYON PANAKKUKANG," *Jurnal Teknologi Elekterika*, vol. 16 (1), no. 1, pp. 43–47, 2019.
- [4] Arismunandar and Artono, *Teknik Tegangan Tinggi*. Jakarta: Pradnya Paramita, 2001.
- [5] J. S. Setiadj, T. Machmudsyah, and Y. Isnanto, "Pengaruh Ketidakseimbangan Beban Terhadap Arus Netral dan Losses pada Transformator Distribusi," *Jurnal Teknik Elektro*, vol. 6, pp. 68–73, 2006.
- [6] Y. Simanora, Panusur, and Tobing, "Analisis Ketidakseimbangan Beban Transformator Distribusi untuk Identifikasi Beban Lebih dan Estimasi Rugi-Rugi pada Jaringan Tegangan Rendah," *Singuda Ensikom*, vol. 7(2), pp. 137–142, 2014.
- [7] PT. PLN, *Standar Kontruksi Sambungan Tenaga Listrik*, no. Mi. Jakarta: PT.PLN, 2015.
- [8] Sugiyono, *Metode penelitian kuantitatif, kualitatif, R&D*. Bandung: Alfabeta, 2019.
- [9] M. Taufiq, "Perhitungan Rugi-Rugi Daya Saluran Distribusi Feeder Bangau Sakti Pada Gi Garuda Sakti Pt. Pln (Persero)," *Jom FTEKNIK*, vol. 8, no. 2016, pp. 1–7, 2021.
- [10] A. M. Siregar, B. Badriana, H. M. Yusdartono, and A. Hasibuan, "Perbaikan Nilai Susut Teknis Jaringan Tegangan Menengah Pada Feeder K.H. 05 (Case Study PLN ULP Kruenggukuh)," *Jurnal Energi Elektrik*, vol. 12, no. 1, p. 24, 2023, doi: 10.29103/jee.v12i1.11708.