

INTEK

(INFORMASI TEKNOLOGI) :
JURNAL PENELITIAN



INTEK

VOL. 7

NO.2

**Hlm.
85-170**

**Makassar
Oktober 2020**

**ISSN
2339-0700**

DAFTAR ISI

- 1. Effect of FSW Heating Base Temperature on Tensile Strength and Hardness of AA 1100 Welds** 85-91
Syamsul Hadi, Agus Setiawan, Pipit Wahyu Nugroho, Adi Dwi Hermansyah, Anas Nur Alfishahri
DOI: 10.31963/intek.v7i2.2623
- 2. Comparative Analysis of Solar Cell Efficiency between Monocrystalline and Polycrystalline** 92-100
Sugianto Sugianto
DOI: 10.31963/intek.v7i2.2625
- 3. Groundwater Pumping Management in Controlling Seawater Up-Coning in The North Coastal Area of Makassar** 101-108
Sugiarto Badaruddin, Akhmad Azis, Muhammad Fadhil Ashari, Miftahul Jannah, Ilham Ali, Muhammad Ihsan
DOI: 10.31963/intek.v7i2.2634
- 4. Design of Microcontroller Based Fire Detector with Output Warning SMS Information and Automatic Extinguisher** 109-115
Abdul Zain, Rudi Hartono, Sri Handani W
DOI: 10.31963/intek.v7i2.2639
- 5. The Use of Nutmeg Shell as a Lightweight Concrete Material** 116-22
Budiman Budiman, Imran Imran, James WTP
DOI: 10.31963/intek.v7i2.2640
- 6. Bearing Capacity Analysis of Spun Pile Foundation in Gas Engine for Electrical Power Plant Project of Selayar** 123-127
Indra Mutiara
DOI:10.31963/intek.v7i2.2643
- 7. Corrosion Rate of Black Chromium Coating Result of Electroplating on Copper** 128-132
Syamsul Hadi, Sza Sya Monica Valeria, Satworo Adiwidodo, Utsman Syah Amrullah, R.N. Akhsanu Takwim, Hilmi Iman Firmansyah
DOI: 10.31963/intek.v7i2.2681
- 8. Public Transport Mode Model Selection for public Transport Users in the City of Makassar Based on the Change of Speed Travel Variables** 133-137
Syahlendra Syahlendra
DOI:10.31963/intek.v7i2.2682
- 9. Adaptive Power Charge Using PID Controller on DC Load Application** 138-144
Farid Dwi Murdianto, Indhana Sudiharto, Irianto Irianto, Ayu Wulandari
DOI: 10.31963/intek.v7i2.2652

10. **Coconut Water as Organic Inhibitor on Corrosion of Low Carbon Steel in 3.5% NaCl Solution** 145-149
Ramang Magga, Muhammad Zuchry, Yusnaini arifin
DOI: 10.31963/intek.v7i2.2690
11. **Exergy Analysis of 1 x 135 MW Jeneponto Steam Power Plant** 150-154
Nur Hamzah, A.M Shiddiq Yunus, Waqva Enno Al Fadiyah
DOI:10.31963/intek.v7i2.2697
12. **Analysis Of Mechanical Properties SMAW (Shielded Metal Arc Welding) Welding Joints Of Portable Electric Hydraulic Jack Frame** 155-159
Andika Wisnujati, Juni Andryansyah
DOI: 10.31963/intek.v7i2.2134
13. **Influence of Curing Conditions on Strength Characteristics of Sea Sand Mortar** 160-166
Irka Tangke Datu, Adiwijaya Ali, Nur Aisyah Jalali, Khairil Khairil
DOI: 10.31963/intek.v7i2.2720
14. **The Effectiveness of Kesum Leaves (Polygonum Minus) In Reducing of Free Fatty Acids In Used Cooking Oil** 167-170
Gervacia Jenny Ratnawaty, Ratih Indrawati
DOI: 10.31963/intek.v7i2.2715



Editorial Team

Editor In Chief

A.M. Shiddiq Yunus, S.T., M.Eng.Sc., Ph.D., State Polytechnic of Ujung Pandang

Deputy Editor in Chief

Ir. Suryanto, M.Sc., Ph.D., State Polytechnic of Ujung Pandang

Associate Editors

Assoc. Professor Ahmad Abu Siada, Ph.D., Curtin University
Prof. Dr. Shingo Okamoto, Ehime University
Yanuar Z. Arief, Dr.Eng., C.Eng., University Technology Malaysia
Dr. Tony Hadibarata, University Technology Malaysia
Parachai Juanuwattanukul, Ph.D., Sripatum University
Dedet Chandra Riawan, S.T., M.Eng.Sc., Ph.D., Sepuluh November Institute of Technology
Yusri Syam Akil, S.T., M.T., Ph.D., Hasanuddin University
Setyawati Yani, S.T., M.T., Ph.D., Indonesia Muslim University

Layout & IT

Muhammad Ruswandi Djalal, S.ST., M.T., State Polytechnic of Ujung Pandang

Administration

Nurdina S.Sos, State Polytechnic of Ujung Pandang
Harli Harli, State Polytechnic of Ujung Pandang
Rudi Rudi, State Polytechnic of Ujung Pandang

Publisher by:

Politeknik Negeri Ujung Pandang
Kampus 1 Gedung Administrasi Lantai II
Jalan Perintis Kemerdekaan KM.10 Tamalanrea
Makassar 90245
E-mail: intek@poliupg.ac.id

INTEK Indexed by:



Member of:



This work is licensed under a [Creative Commons Attribution-ShareAlike 4.0 International License](https://creativecommons.org/licenses/by-sa/4.0/).

[View My Stats](#)

Focus And Scope

Editorial Teams

Reviewer Teams

Publication Ethics

Author Guideline

Peer Review Process

Abstracting and Indexing

Template

Copyright Notice

Statistics



USER

Username
Password
 Remember me

NOTIFICATIONS

- [View](#)
- [Subscribe](#)

BARCODE E-ISSN



TOOLS



LANGUAGE

Select Language
English

JOURNAL CONTENT

Search
Search Scope
All

Browse

- [By Issue](#)
- [By Author](#)
- [By Title](#)
- [Other Journals](#)

FONT SIZE



KEYWORDS

3d Antioxidants Baluran National Park
Clove Oil Fuzzy Logic Controller, PI
Controller, PID Controller, Single Phase
Induction Motor Gas chromatography-
mass spectrometry Peat Water ,
Moringa oleifera, Poly Aluminum
Chloride, Organic matter Polygonum
Minus, Free Fatty Acid, Used Cooking
Oil, Polyphenols Propanol Safflower
Sea sand Web-based e-ticket blackbox
method bored pile, CPT, bearing
capacity curing condition extreme
programming mortar river sand
strength characteristic tourism

www.fabbly.com

Design of Microcontroller Based Fire Detector with Output Warning SMS Information and Automatic Extinguisher

Abdul Zain^{1,a}, Rudi Hartono^{2,b} dan Sri Handani W³

^{1,2} Departement of Electrical Engineering, Sekolah Tinggi Teknologi Bontang, Jl Letjen S. Parman No 65 Bontang

³ Departement of Informatics Engineering, Sekolah Tinggi Teknologi Bontang, Jl Letjen S. Parman No 65 Bontang

^a jainbtg2013@gmail.com

^{b1} rudi.hrt@gmail.com



Abstract— Conflagration is an unpredictable tragedy. It may occur whether in the woodland areas or in the residential areas. Typically, it would only be recognized if indeed the flames spread and the smoke intensified. This study aims to detect fires using the MQ-2 smoke sensor, DS18B20 temperature sensor, and fire sensor. Using Arduino Uno as the controller, this system's output is in the form of an alarm buzzer, Short Message Service (SMS) information using SIM800L, and an automatic fire pump. This system operates to detect the temperature shifts, the smoke concentration and the existence of a fire point which triggers an alarm in the form of a siren if two out of the three sensors are activated. It, then, sends information by Short Message Service (SMS) and automatically triggers the pump as the result. The fire sensor can detect hotspots with a maximum distance of 80 cm and the DS18B20 temperature sensor has an average reading error of 0.27 ° C with a maximum reading error of 0.5 ° C. The MQ-2 smoke sensor can detect smoke where the change in smoke concentration is directly proportional to the sensor output voltage. There are three conditions to determine fire conditions, namely the temperature sensor reads more than equal to 55 ° C and the fire sensor is active, or the temperature sensor reads more than equal to 55 ° C and the smoke sensor reads more than equal to 1000 ppm, or the fire sensor is active and smoke sensor reads greater than equal to 1000 ppm.

Keywords—component; conflagration, MQ-2 smoke sensor, fire sensor, DS18B20 temperature sensor, Sim800L, automatic extinguishing.

I. Introduction

Fire is an oxidation process of three elements air, fuel, and heat source [1]. Conflagration is an unpredictable tragedy [2]. This disaster can occur in the forest areas as well as in residential areas, this incident is not expected by the community because it will cause material, psychological losses and allow for casualties.

The fires in urban areas are generally caused by an electrical short circuit (short circuit) on the power cable, a leak in the LPG gas cylinder pipe, or human negligence, such as throwing cigarette butts carelessly. Apart from those caused by human factors, fire disasters can also be caused by natural factors such as lightning, earthquakes, volcanic eruptions, long droughts etc [3].

In general, the fires will only be known if the flames have enlarged and smoke has risen. These conditions will cause casualties, the detriment which are not small and the cessation of business activities or causing environmental damage [4]. When the fires occur, the community worked together to extinguish before the firefighters arrived, the real fact that, the problems were often occurred when firefighters arrive at the location are due to several factors, are delay in information, congested roads to the location, areas that are difficult to reach and the readiness of the officers [3].

To suppress the fire numbers, it is need to take an action which prioritizes safety. Warning of signs of fire is one solution to fire hazards. Signs of fire can be detected because every fire always emits smoke and heat [5]. Based on the above conditions, a fire detection device is designed with information output of an SMS gateway and automatic extinguishing.

This tool is designed for early detection of fire symptoms by using several sensors such as, MQ-2 smoke sensor, fire sensor, DS18B20 temperature sensor

with the Arduino Uno microcontroller as a data processor. By this sensor sensing, if two of the three sensors detect early signs of fire, it will activate an alarm in the form of a siren and SMS will be sent to the contact which has been set as information and it will turn on the pump to spray water into the area where the fire is happening so it does not enlarge.

II. Research Methodology

A. Research Schedule

The research has been conducted on January 2020 to July 2020. This research activity consists of two parts; (1) design the tools and (2) test the tools. The research was conducted at the Laboratory of Electrical Engineering Program Study, Bontang Engineering College.

B. Research Stages

Steps of the research can be seen in figure 1.

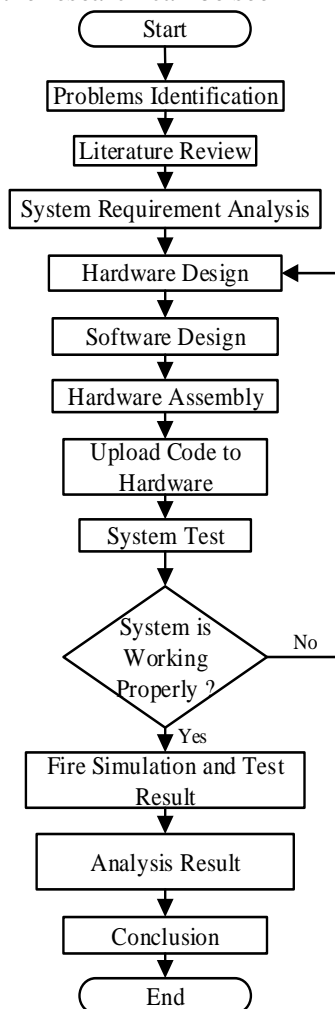

Figure 1. Research Flowchart

C. System Architecture

System architecture is a general description of the system to be designed and built. Figure 2 shows the fire detection device design model which will be built in accordance with literature review and system requirement analysis.

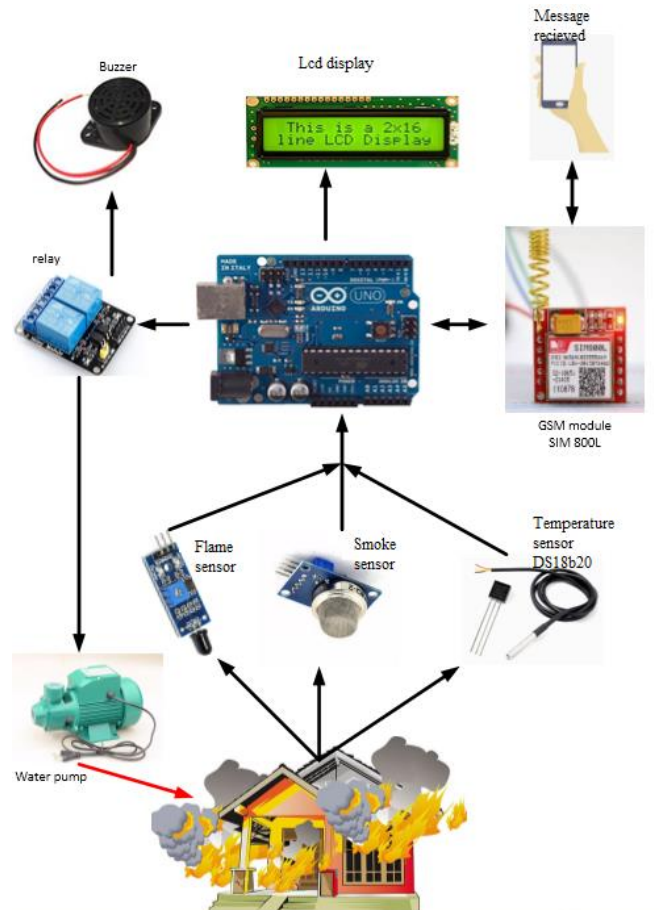

Figure 2. System Architecture

In figure 2, it can be seen that the configuration of the fire detection and automatic extinguishing devices to be built consists of input, process, and output. From the input side, this research using several sensors consisting of a DS18b20 temperature sensor, MQ-2 smoke sensor and flame sensor. Arduino Uno is used as a data processor which will receive data from sensors and will be processed to determine conditions that are indicated as conflagration. The output of this system is in the form of a buzzer alarm, Sim 800L module to sent information of conflagration, the LCD is used to display sensor data and automatic start of the pump.

D. System Design

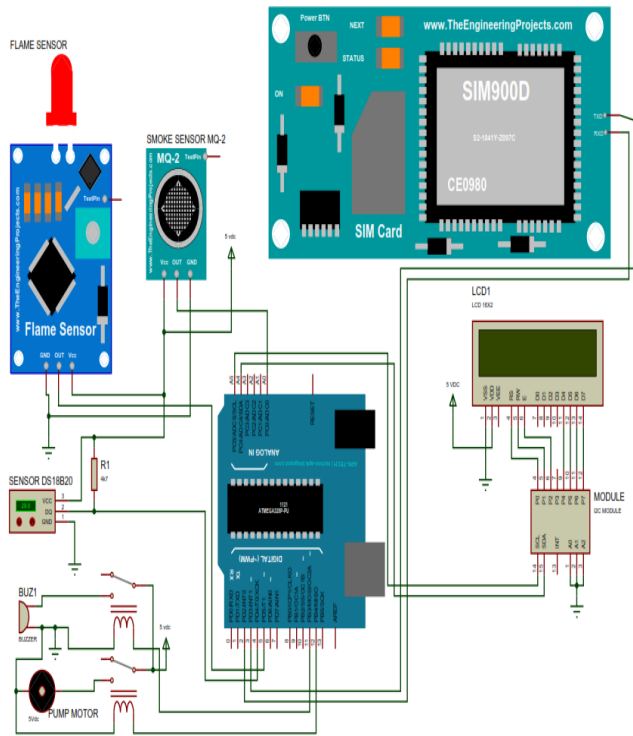

Figure 3. System Design

Figure 3 is a built system design. The Arduino Uno microcontroller pin configuration for the sensors is set up as follows:

1. The Flame sensor output signal is a digital, the DO sensor pin is connected to pin 5 of the microcontroller.
2. The DS18B20 sensor output signal is a digital, the pin Out sensor is connected to pin 4 of the microcontroller.
3. The MQ-2 sensor output signal is an analog, the pin A out sensor is connected to pin A0 on the microcontroller.
4. The I2C module combined with LCD 16x2 to economize pin of microcontroller. on the SDA and SCL pins I2C the LCD module is connected to the A4 and A5 pins of the microcontroller.
5. The Sim 800L module can be communicated with the microcontroller by using serial communication, the pin RX, TX module is connected to the pin 2 and pin 3 on the microcontroller.

6. To activate the buzzer and water pump, an automatic switch in the form of a relay is used. The signal relay pins are connected to pin 11 and pin 12 on the microcontroller.

E. Flowchart System

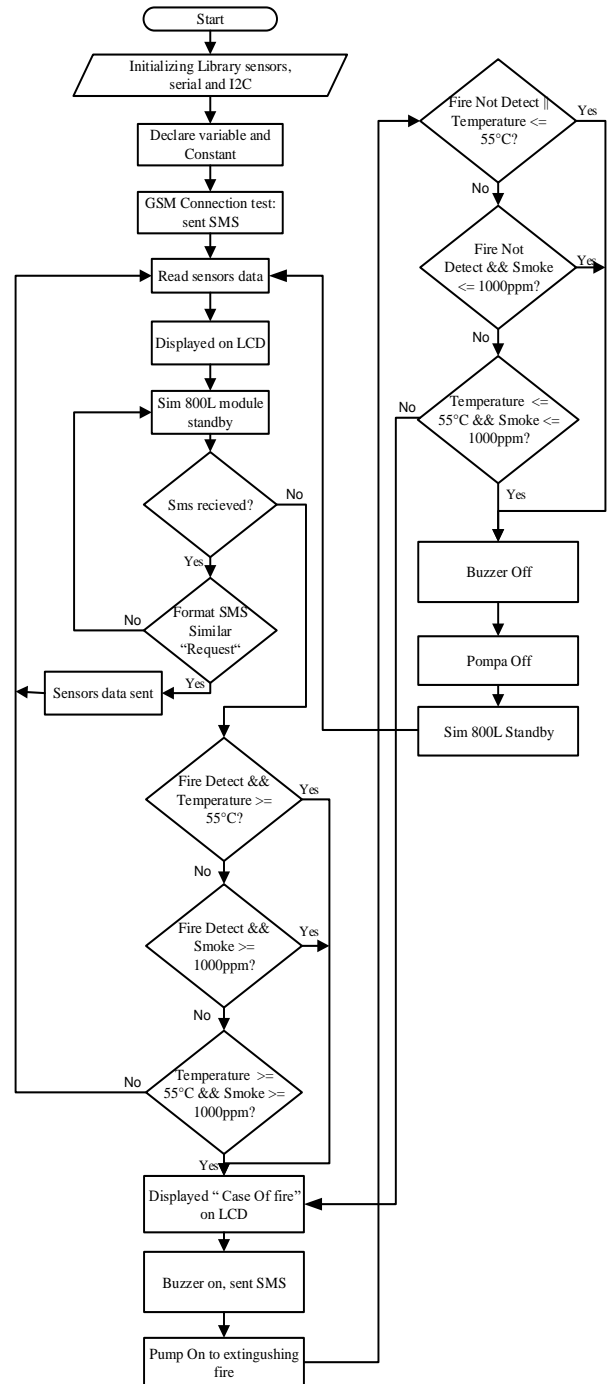

Figure 4. Flowchart system

Fire alarm system and automatic extinguisher are designed with basic capabilities based on Self-Monitoring, Analyzing & Reporting Technology (SMART) [6]. The SMART system is a system designed

to detect potential fires, analyze in the presence of three sensors are used, if two of the three sensors are active, so the microcontroller will give commands to send information to the contact number that has been previously arranged. The microcontroller will activate the pump automatically to make extinguisher. The Information is received in the form of SMS is fire warning information to call the authorities to further handle the fire. There are how to the system is built as follows:

1. Initializing library, serial communication and I2C communication.
2. Declared variables.
3. Sent SMS "Test connection SMS" the first time the system is turned on.
4. Read and process the data from sensors and displayed on the LCD.
5. Sensor of the data can be accessed through via mobile phone by sending an SMS with the format "Request".
6. Set point of value sensor to indicate the fire
 - a. The flame sensor is LOW
 - b. The temperature sensor is more than equal 55°C [5].
 - c. The smoke sensor is more than equal 1000 ppm [7].
7. There are three conditions are indicated as fire conditions:
 - a. The flame sensor is LOW and the temperature sensor is more than equal set point value.
 - b. The flame sensor is LOW and the smoke sensor is more than equal set point value.
 - c. The temperature sensor and smoke sensor are valued more than equal to set point value.
8. If one of the conditions above is achieved, it will activate the buzzer, it sends message fire warning information to the contact number that has been set, displays the status "case of fire" in LCD, it will activate the pump to perform a extinguisher.

9. If the sensor value is less than the set point value, the system will deactivate the pump, the buzzer and LCD will display the value sensor.
10. The system will return to monitoring mode.

III. Result and Discussion

A. Hardware Assembly

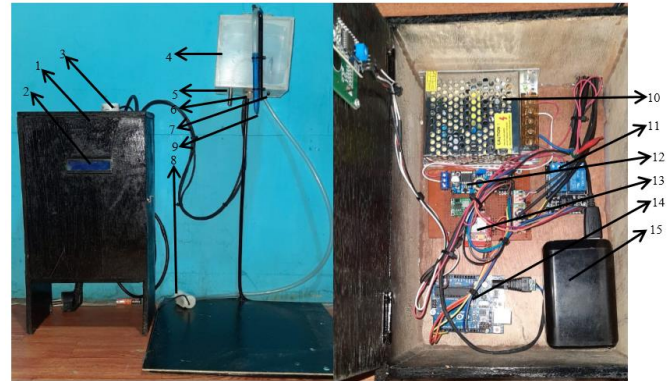

Figure 5. Hardware Assembly

The design of the fire detector above is still a prototype. Figure 5 is the result of the hardware assembly used in this research.

caption 5 as bellows :

- | | |
|-------------------|---------------------|
| 1. Box panel | 9. Sprinkle |
| 2. LCD 16x2 | 10. Power supply |
| 3. Buzzer | 11. Relay |
| 4. Censors box | 12. DC-DC converter |
| 5. Censor DS18B20 | 13. Sim 800L |
| 6. Censor MQ-2 | 14. Arduino Uno |
| 7. Flame sensor | 15. Battery |
| 8. Pump | |

B. Sim 800L Test Result

In this research, using by the Sim 800L module as a component that functions to send SMS information to the contact number that has been set. It aims to ensure to send the SMS information which can be received to the contact number that has been set. In module of operation uses a Led indicator as a cellular network signal status. The indicators are as follows:

1. It is blinking every second it indicates that the module is running but has made connection to the cellular network yet.

2. It is blinking every two seconds it indicates that *General Package Radio Service (GPRS)* data is active.
3. If it is blinking every 3 seconds indicates the module is connected to the cellular network and can send and receive calls or Short Message Service (SMS).

Table 1. AT Command Sim 800L module

Syntax	Description
AT+COPS	Operator Selection
AT+CREG	Registrasion Network
AT+CSQ	Signal Quality Report
AT+CFUN	Set Phone Functionality
AT+CMGF	Select SMS Message Format
AT+CMGS	Send SMS Message
AT+CMGR	Read SMS Message
AT+CNMI	New Message Indication

Table 1 above is some of the commands are used to access the Sim 800L by means of serial communication or has been written in the code program. The result of the test are as in figure 6.

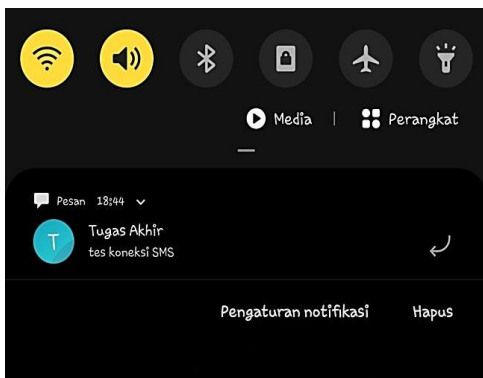

Figure 6. SMS Recieved

C. Temperature Censor Test Result

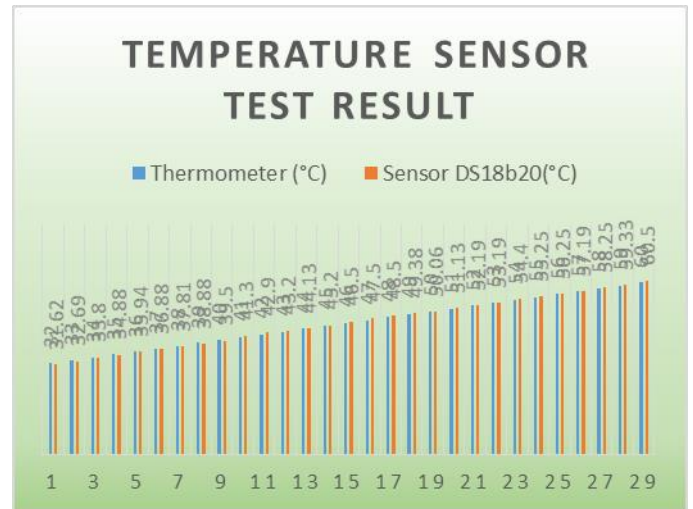

Figure 7. Temperature Censor Test Result

The results shown in figure 7 are a test of the DS18b20 temperature censor which is compared with a mercury thermometer by blowing hot air using a heat gun.

D. Flame Censor Test Result

Table 2. Flame Censor Test Result

Ranges	Flame Censor	Buzzer	LCD Display
10 cm	LOW	On	Fire Detected
20 cm	LOW	On	Fire Detected
30 cm	LOW	On	Fire Detected
40 cm	LOW	On	Fire Detected
50 cm	LOW	On	Fire Detected
60 cm	LOW	On	Fire Detected
70 cm	LOW	On	Fire Detected
80 cm	LOW	On	Fire Detected
90 cm	HIGH	Off	Fire Not Detected
100 cm	HIGH	Off	Fire Not Detected

This test is done by providing a fire point just below the flame censor and measuring the maximum distance the flame censor can detect fire. The test results are shown in table 2.

E. Gas Censor Test Result

Table 3. Gas Censor Test Result

Condition	Censor MQ-2	Censor Volt
Without Smoke	0 ppm	0,16 volt
Thin Smoke	334 ppm	0,80 volt
Medium Smoke	2345 ppm	1,13 volt
Thick Smoke	4141 ppm	1,19 volt

The test is done by giving smoke to the smoke censor with different levels of concentration. The conditions change in smoke concentration directly proportional to

the increase PPM value that will be displayed on the LCD. The test results are shown in table 3.

F. Third Conditions Fire Detector Testing

1. Condition 1 Test Result

Table 4. Condition 1 Test Result

Temp. Censor	Flame Censor	Sim 800L	Buzzer	Pump	LCD display
52,68°C	Low	Stand by	Off	Off	Censors data
57,19°C	High	Stand by	Off	Off	Censors data
55,18°C	Low	Sent SMS	On	On	Case of Fire
56,38°C	Low	Sent SMS	On	On	Case of Fire
57,20°C	Low	SMS sent	On	On	Case of Fire
61,28°C	Low	SMS sent	On	On	Case of Fire

2. Condition 2 Test Result

Table 5. Condition 2 Test Result

Flame Censor	Smoke Censor	Sim 800L	Buzzer	Pump	LCD display
High	0 ppm	Stand by	Off	Off	Censors data
Low	441 ppm	Stand by	Off	Off	Censors data
High	1338 ppm	Stand by	Off	Off	Censors data
Low	2125 ppm	SMS sent	On	On	Case of Fire
Low	2133 ppm	SMS sent	On	On	Case of Fire
Low	1153 ppm	SMS sent	On	On	Case of Fire

3. Condition 3 Test Result

Table 6. Condition 3 Test Result

Temp. Censor	Smoke Censor	Sim 800L	Buzzer	Pump	LCD display
30,81C	0 ppm	Stand by	Off	Off	Censors data
59,20° C	300 ppm	Stand by	Off	Off	Censors data
47,69° C	1720 ppm	Stand by	Off	Off	Censors data
57,50° C	1574 ppm	SMS sent	On	On	Case of Fire
60,15° C	3140 ppm	SMS sent	On	On	Case of Fire

G. Discussion

From the test results of table 4 to table 6 above, it can be concluded that when two of the three sensors detect more than the same set point value, it will indicate a fire

DOI : <http://dx.doi.org/10.31963/intek.v7i2.2639>

and the system will activate the buzzer, send an SMS and activate the pump, the received SMS information is as in figure 8. But if one of the two sensors is less than the set point value, the system will return to monitoring mode

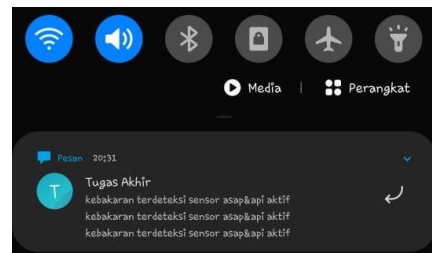

Figure 8. SMS Received

IV. Conclusion

Based on the design and testing of fire detector with output warning information and automatic extinguisher which have been carried out and the problems which have arisen, there are some conclusions can be drawn, including:

1. It has been designed successfully and made a fire detector with warning information and automatic extinguisher using the DS18B20 temperature sensor, MQ-2 smoke sensor, fire sensor, sim 800L module, buzzer, pump, and relays based on Arduino Uno microcontroller can work according to the design and program made.
2. The flame sensor can detect hotspots or fire with a maximum distance of 80 cm and the DS18B20 temperature sensor has a maximum reading error of +/- 0,5°C.
3. The MQ-2 smoke sensor can detect smoke where the change in smoke concentration is directly proportional to the sensor output voltage.
4. There are three conditions for determining fire conditions, are temperature sensor reads greater than equal to 55 ° C and active fire sensor, or temperature sensor reads greater than equal to 55 ° C smoke sensor reads greater than equal to 1000 ppm, or active fire sensor and smoke sensor reads more than equal to 1000 ppm.
5. The output of this system is a buzzer alarm, SMS information with the sim800L module and automatic shutdown can work as expected and it can help fight fires

Acknowledgement

The authors would like to thank to Head of Electrical Engineering Study Program, STITEK Bontang, Head of Electrical Engineering Laboratory, STITEK Bontang, Lecturers and Staff of STITEK Bontang who have made positive contributions to the completion of this research.

References

- [1] Fatmawati, Ratri. "Audit Keselamatan Kebakaran Di Gedung PT. X Jakarta Tahun 2009" (Fire Safety Audit at PT. X Jakarta Year 2009). Skripsi. Fakultas Kesehatan Masyarakat, Kekhususan Keselamatan dan Kesehatan Kerja, Universitas Indonesia, Depok. 2009.
- [2] Sutikno, Tole, Wahyu Sapto Aji, dan Rahmat Susilo. "Perancangan Alat Pendeteksi Kebakaran Berdasarkan Suhu dan Asap Berbasis Mikrokontroler AT89S52" (Design of a fire detection device based on temperature and smoke based on the AT89S52 microcontroller). TELKOMNIKA, 4(1), pp. 49-56. 2006.
- [3] Yendri, Dodon, Wildian, dan Amalia Tiffany. "Perancangan Sistem Pendeteksi Kebakaran Penduduk Pada Daerah Perkotaan Berbasis Mikrokontroler" (Microcontroller-Based Design of Resident Fire Detection Systems in Urban Areas). Seminar Nasional Sains dan Teknologi. Jakarta, Indonesia: Fakultas Teknik Universitas Muhammadiyah Jakarta. 2017.
- [4] Sipayung, Lawmen Miane, "Rancangan Sistem Deteksi Kebakaran dan Pemadaman Otomatis Berbasis Mikrokontroler Atmega8535" (The Design of Fire Detection and Automatic Extinguishing Systems Based on the Atmega8535 Microcontroller) .Skripsi. Fakultas Ilmu Matematika dan Ilmu Pengetahuan Alam, Universitas Sumatera Utara, Medan. 2017.
- [5] Zain, Abdul. "Rancang Bangun Sistem Proteksi Kebakaran Menggunakan *Smoke* dan *Heat Detector*"(Fire Protection System Design using Smoke and Heat Detector). Journal INTEK. 3(1), pp.36-42. 2016.
- [6] Apriyandi, Subhan. "Rancang Bangun Sistem Detektor Kebakaran Via Handphone Berbasis Mikrokontroler". (Microcontroller Based Mobile Fire Detector System Design), Jurnal Untan. Vol (1) no.1, 2013.
- [7] Nurrochim, Faisal. "Simulasi Alat Pendeteksi Kebakaran Menggunakan Censor Asap MQ-2, Censor Suhu LM35, dan Module Wifi ESP8266 Berbasis Mikrokontroler Arduino" (Simulation of a fire detection tool using the MQ-2 smoke sensor, LM35 temperature sensor, and the ESP8266 WiFi module based on the Arduino microcontroller). Undergraduate thesis, Repository UnmuhJember. 2017.