

# Comparison of FLC and ANFIS Method to Keep Constant Voltage Based on Flyback Converter

Nila Nanda Nismayanti<sup>1,a,\*</sup>, Indhana Sudiharto<sup>1,b</sup>, and Diah Septi Yanaratri<sup>1,c,\*</sup>

<sup>1</sup>Electrical Engineering Department Politeknik Elektronika Negeri Surabaya, Surabaya Indonesia

<sup>a</sup>anandanila19@gmail.com

<sup>b</sup>indhana@eepis-its.edu,

<sup>c,\*</sup>diahsepti@pens.ac.id (Corresponding Author)



**Abstract**— The development of technology suggest humans to always create certain types of renewable innovation, which are useful for public facilities. Especially in information technology we always need to do the things like work, school and etc. using gadget. To reduce various kind of problems on battery health, needs an innovation about charger station in public places. This charger station has a single input single output system so that using just 1 battery source can be used for charging. To realize this charging system, a flyback converter that is capable of working with single input single output is used, which is of course controlled by the Adaptive Neuro Fuzzy Inference System (ANFIS) so that the resulting output voltage remains constant, which is 19 V.

**Keywords**— Flyback Converter, Adaptive Neuro Fuzzy Inference System, Constant Voltage

## I. Introduction

In theory and practice, fuzzy systems are great interest for the researchers. Adaptability, flexibility and rapidity have been developed by the characteristics of fuzzy logic controllers and NN (Neural Network). Fuzzy logic has low adaptability but good on exegesis ability. On the other side, neural networks require a lot of learning data which is difficult to determine but neural networks are able to proceed to all kinds of nonlinear functions. The Fuzzy Inference System (FIS) with Sugeno type which has many inquiries in certain fields is ANFIS, such as functional approaches, intelligent control and time series prediction. The characteristics of the fuzzy logic system performance when compared to the FIS and ANFIS systems in the testing process, it is much better to use FIS and ANFIS. Fuzzy logic in few years has been proposed as a new artificial intelligence

but fuzzy logic is difficult to define membership functions and the results still show oscillations in steady state response. Thus, this issue can be completed by using ANFIS, through the selection of domains from automatic functions and the basis of fuzzy rules that are automatically generated. Three parameters that should be known before designing ANFIS are error, delta error and output. This paper applies the triangle function and  $7 \times 7$  membership function to determine the best control performance and response voltage. In this research, to preserve a constant voltage based on a flyback converter we used a comprehensive experimental between ANFIS and FLC. Comparison of ANFIS and FLC algorithms is the main focus in this research. for constant voltage will allow high efficiency, good reaction, and a supple form that is credible below a various of battery voltage condition.

## II. Research Methodology

### A. Research Method

This research includes battery lithium ion as power source of flyback converter multi output and adaptive neuro fuzzy inference system (ANFIS) to regulate the output voltage of the converter. Figure 1 shows the diagram block of the system. At the diagram block using flyback converter as the main component to transform voltage from 42 V to 19 V and helped by ANFIS controller to keep the voltage constant as the design of this simulation.

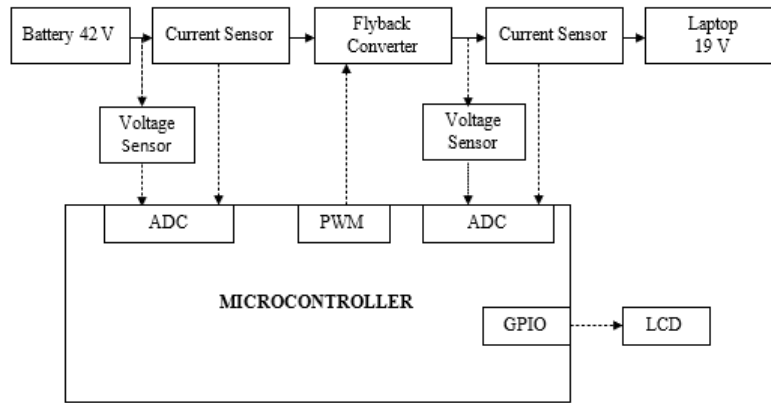

Figure 1. Diagram block system

**B. Flyback Converter**

A DC-DC converter that has a topology such as a buck boost converter with inductors separated to form a transformer, namely a flyback converter, the function of the transformer is for galvanic isolation between input and output. To obtain a flyback converter from a buck boost converter, replace the inductor with a transformer. The following equation (1) shows the output voltage equation of the flyback converter

$$V_o = V_s \left( \frac{D}{1-D} \right) \left( \frac{N_1}{N_2} \right) \tag{1}$$

$N_1$ =Total windings of the primary of transformer.  
 $N_2$ =Total windings of the secondary of transformer.

This decrease in the voltage gain expression can be analyzed from the two switch states (Q1) with a system similar to a buck-boost converter. When the switch Q1 is ON, the input voltage appearing on the primary side of the transformer, so that the energy in the magnetizing inductance of the transformer increases. Because it shows the polarity of the point, the diode D1 appears negative voltage and does not conduct. Capacitor (C1) comply the current load demand, during this state. When switch Q1 is off, the current stored in  $L_m$  do not immediately zero. Due to Faraday's law of electromagnetic induction, the diode D1 begins to conduct and transfers energy from the inductor to the capacitor (C1).

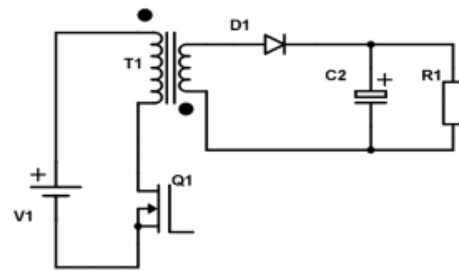

Figure 2. Flyback Converter Circuit

To calculate the value of the converter component will be explained in equations (2) to (5).

$$L_m = \frac{(V_{dc \min} \times D_{maks})^2}{2 \times P_{in} \times F_s \times K_{rf}} \tag{2}$$

$$N_p (min) = \frac{L_m \times I_{maks}}{B_{sat} \times A_c} \times 10^4 \tag{3}$$

$$C_1 = \frac{I_o \times D}{F \times \Delta V_o} \tag{4}$$

After knowing the equation to find the value of the converter component, table 1 shows the using of parameters in this research.

Table 1. The parameter of Flyback Converter

No	Parameter	Value
1	Input Parameter	42 V
2	Output Parameter	19 V
4	Frequency	40 kHz
5	Np <sub>1</sub>	32 Turn
6	Ns <sub>1</sub>	14 Turn
7	Inductor Magnetization (Lm)	86,4 μH
8	Capacitor Output 1 (Co)	2,25 mF

C. Fuzzy Type 1 Logic Controller

Inference process and human feeling is identical to fuzzy logic. Fuzzy logic consists of a rule base and a fuzzy set of linguistic variables. In this research, a flyback converter system is simulated to stabilize the voltage using fuzzy logic with the Sugeno inference system method using Matlab software as a calculation. There are three stages in fuzzy logic calculations, namely: (1) Fuzzification; (2) Inference Engine; (3) Defuzzification.

1. Fuzzification

The transformation system of the craps input value called fuzzification. In this condition, the value of the output variable is named duty cycle and the value of the input variable consists of error and delta error. In classical logic, a set has a membership of a point determined by standard values: 1 where the point be included to the set, 0 otherwise. In fuzzy logic, an element can be part of a set: its degree of membership is represented by a value between 0 and 1. A is a fuzzy set type-1, which is based on a singular variable,  $x \in X$ , may be explained as follows:

$$A = \{ (x, \mu_A(x)) \mid \forall x \in X \} \tag{5}$$

and also can be written as:

$$A = \int_{x \in X} \mu_A(x) / x \tag{6}$$

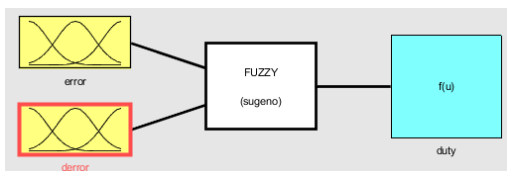

Figure 3. Variable Input and Output FLC

In Figure 3, it can be seen that the variable membership function with a triangular shape and the formula used to determine the  $\mu$  (miu) value.

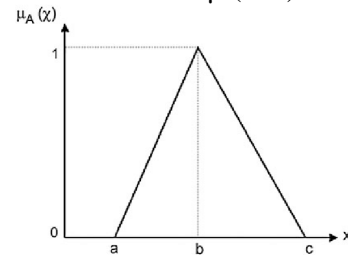

Figure 4. Triangular Membership Function

To determine the degree of membership from the designed fuzzy set is required the function of the set. This function is built based on the equation of the line formed by the fuzzy set. Examples of functions from the set of triangles as follows:

$$f(x, a, b, c) = \begin{cases} 0, & x \leq a \\ \frac{x-a}{b-a}, & a \leq x \leq b \\ \frac{c-x}{c-b}, & b \leq x \leq c \\ 0, & c \leq x \end{cases}$$

where  $f(x, a, b, c)$  is the degree of membership,  $x$  are the values of the variables,  $a, b, c$  respectively are the start, middle and end values of the variable.

2. Inference Engine

In forming the duty cycle output, the inference engine uses error variable and delta error variable. In the ANFIS design, 49 rules are used, as shown in Table 2, to change the fuzzy region and adjust it to the output using the AND operator, after this system takes the lowest value from the rule base or the MIN method is worked. If the problem has been solved, the output will describe the fuzzy rule base that contributes to each problem. The input and output membership functions will be determined by the rules that will exist in the linguistic inference process also the rules have the right to "IF-THAN".

Table 2. 49 Rule-Base of FLC

e / Δe	NL	NM	NS	ZE	PS	PM	PB
NL	NL	NL	NL	NL	NM	NS	ZE
NM	NL	NL	NL	NM	NS	ZE	PS
NS	NL	NL	NM	NS	ZE	PS	PM

Z	NL	NM	NS	ZE	PS	PM	PL
PS	NM	NS	ZE	PS	PM	PL	PL
PM	NS	ZE	PS	PM	PL	PL	PL
PL	ZE	PS	PM	PL	PL	PL	PL

Rule 1: If x is A1 and y is B1 then z is f1(x, y)

Rule 2: If x is A2 and y is B2 then z is f2(x, y)

3. Defuzzification

The fuzzy set is the input form of the defuzzification process obtained from the arrangement of fuzzy rules, while the generating output is a number in the fuzzy set domain in the shape of a duty cycle. The defuzzification process uses a weight average method, in this Sugeno type. From Figure 5, it can be seen that the surface of fuzzy logic controller determine on Figure 5.

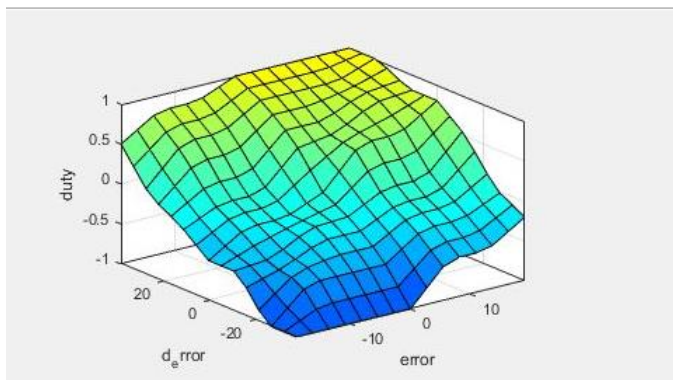

Figure 5. Fuzzy Surface

D. Adaptive Neuro Fuzzy Inference System (ANFIS)

Sugeno's first rule fuzzy inference system in a multilayer feed-forward adaptive neural network was mapped by ANFIS to improve performance by increase interesting features such as fast and precise learning. To decide the best allocation of functions, the ANFIS system mapping the relationship between input values and output values using a hybrid learning method. In this ANFIS architecture, artificial neural networks (ANN) and fuzzy logic are used. This is considered to make the system formed by ANFIS less dependent on expert knowledge and more systematic. Basically, five layers are used to construct this inference system. The node function describes the ANFIS layer consisting of multiple nodes. That input parameter of this layer is obtained from nodes in the previous layer. In this system the ANFIS procedure is illustrated, using two inputs (x, y) and one output (fi) as assumptions for simplicity. The fuzzy if-then type of sugeno is the content of the basic rules of ANFIS. For a first order two-rule Sugeno fuzzy inference system, the two rules may be stated as:

- Layer 1: The adaptive node function is the content of this layer, which are described as follows:

$$O_{1,i} = \mu_{A_i}(x) \quad \text{for } i = 1, 2$$

$$O_{1,i} = \mu_{B_{i-2}}(y) \quad \text{for } i = 3, 4$$

A and B are the linguistic tags, where x and y are the input nodes, l(x) and l(y) are the membership functions which are usually used a triangular structure with max and min identical to 1 and 0 respectively, as follows:

$$O_{1,i} = \mu_{A_i}(x) \quad \text{for } i = 1, 2$$

where  $a_i, b_i, c_i$  are the value set. When the value has change, the triangle function varies. The premise parameter is the name of these parameter.

- Layer 2: Fixed node is the node that used in this layer, signed by a circle and marked P, with the node function to be multiplied by input signals to serve as output

$$O_{1,i} = \omega_i = \mu_{A_i}(x) \cdot \mu_{B_i}(y) \quad \text{for } i = 1, 2$$

- Layer 3: Fixed node is the node that used in this layer, signed by a circle and marked N, with the node function to normalize the firing strength by calculating the ratio of the it node firing strength to the sum of all rules' firing strength

$$O_{3,i} = \varpi_i = \frac{\omega_i}{\sum \omega_i} = \frac{\omega_i}{\omega_1 + \omega_2} \quad \text{for } i = 1, 2$$

- Layer 4: The function nodes in this layer are signed with a square, the nodes in this layer are adaptive nodes, as follows :

$$O_{4,i} = \varpi_i \cdot f_i \quad \text{for } i = 1, 2$$

where  $f_1$  and  $f_2$  are the fuzzy if-then rules as follows:

- Rule 1: if x is  $A_1$  and y is  $B_1$  then

$$f_1 = p_1x + q_1y + r_1$$

- Rule 2: if x is  $A_2$  and y is  $B_2$  then

$$f_2 = p_2x + q_2y + r_2$$

where:  $p_i, q_i$  and  $r_i$  are the value set, referred to as the consistent value

- Layer 5: Fixed node is the node that used in this layer, with node function to compute the overall output by

$$O_{5,i} = f_{out} = \sum_i \varpi_i \cdot f_i = \text{overall output}$$

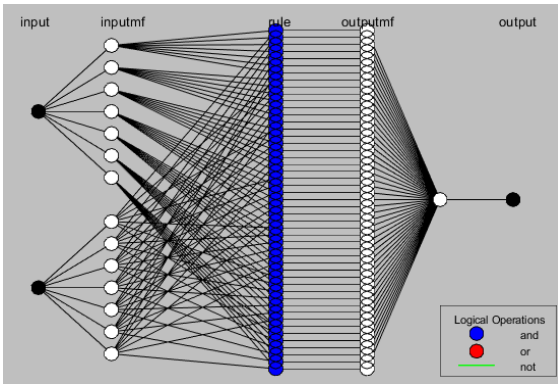

Figure 6. ANFIS Structure

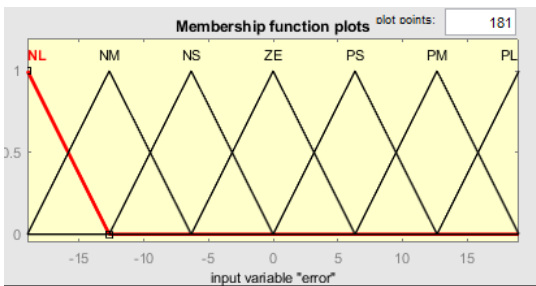

Figure 7. Error MF rules of ANFIS

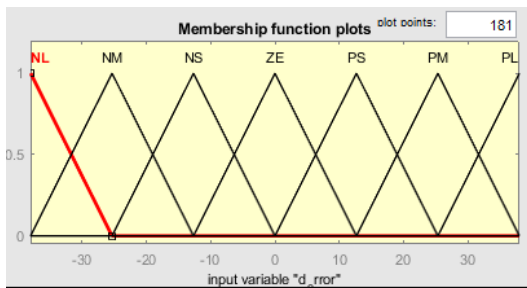

Figure 8. Delta Error MF rules of ANFIS

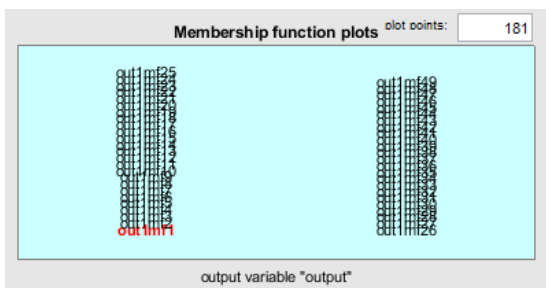

Figure 9. Output MF rules of ANFIS

### III. Results and Discussion

In this section, explaining about testing of flyback converter. ANFIS and FUZZY-1 is used to adjust the output voltage of flyback converter reach setting point at

19 V. In Figure 10 determine the circuit of the simulation.

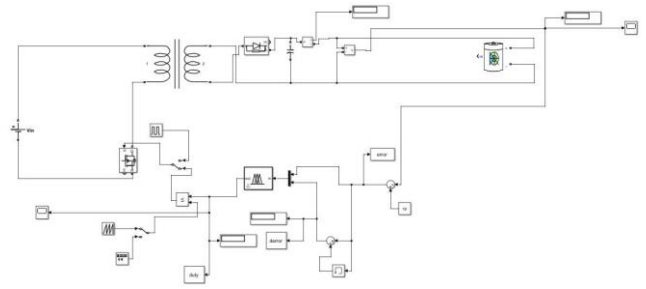

Figure 10. Flyback Converter Integration Simulation with ANFIS Controller

Figure 10 shows an integrated simulation circuit consisting Flyback Converter and a control circuit using ANFIS control to adjust the output of the Flyback Converter.

In this simulation, the battery charging voltage is 19 V. In picture below we can see the performance of ANFIS controller to keep a constant voltage of flyback system, we also compare the graph between openloop and closeloop condition at Figure 11.

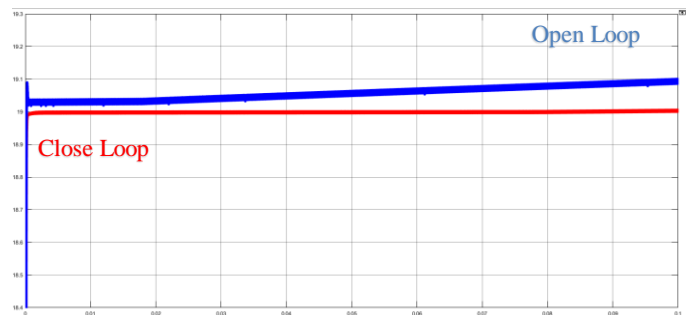

Figure 11. The comparison between open loop and close loop simulation

Table 3. Voltage Output Flyback Converter

V <sub>s</sub> (Volt)	SOC (%)	V <sub>out</sub> (Volt)
42	100,00	19.00
41	93,55	19.00
40	87,10	19.00
39	80,65	19.00
38	74,19	19.00
37	67,74	19.00
36	61,29	19.00



After performing the integration simulation, to prove that the control works according to the set points, we can compare the performance between ANFIS and FUZZY-1

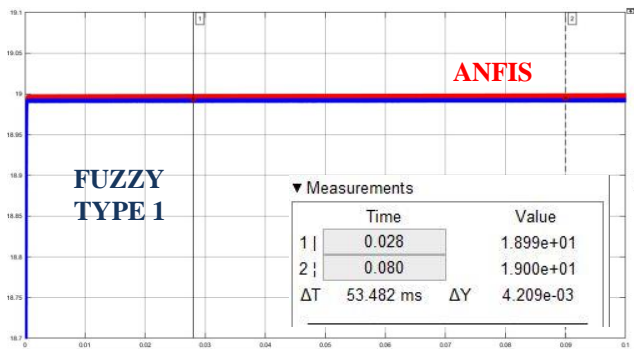

Figure 12. The comparison between ANFIS and FUZZY-1 simulation at SOC 100%

In addition, from Figure 12 blue graphic controlled by fuzzy type 1 and red graphic controlled by ANFIS at SOC 100%. it is the close loop test simulation using MATLAB software. To get a constant voltage, in this research close loop system is using FLC and ANFIS control with value voltage set at 19 V. So, from Figure 12 it is known that when using FLC, the resulting average value is obtained less than 19 V between while the average accuracy generated when using ANFIS.

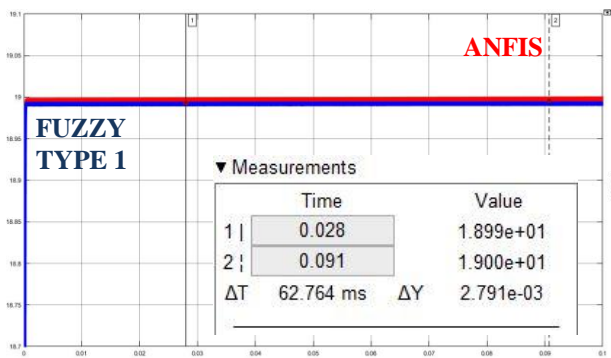

Figure 13. The comparison between ANFIS and FUZZY-1 simulation at SOC 87.10%

From Figure 13 blue graphic controlled by fuzzy type 1 and red graphic controlled by ANFIS at SOC 87.10%. By using fuzzy type 1 generated the output less than the set point, with the output is 18.99V while using ANFIS the output reach the set point at 19V, even though using the same battery parameter data.

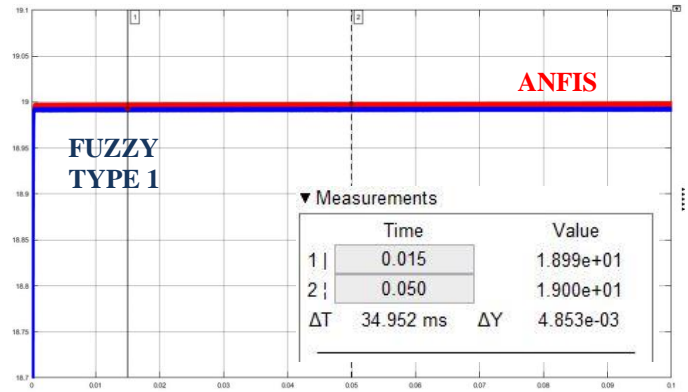

Figure 14. The comparison between ANFIS and FUZZY-1 simulation at SOC 74.19%

From Figure 14 blue graphic controlled by fuzzy type 1 and red graphic controlled by ANFIS at SOC 74.19%. By using fuzzy type 1 generated the output less than the set point, with the output is 18.99V while using ANFIS the output reach the set point at 19V, even though using the same battery parameter data.

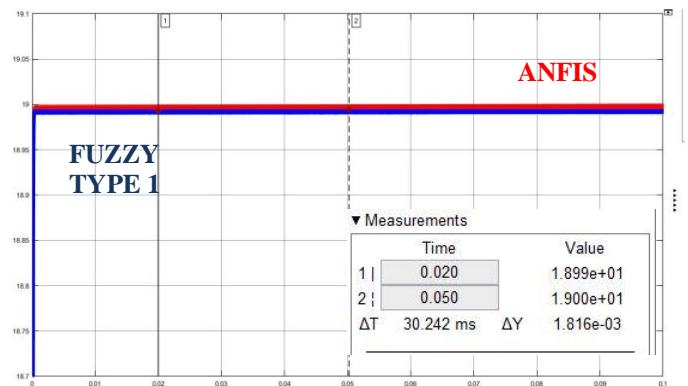

Figure 15. The comparison between ANFIS and FUZZY-1 simulation at SOC 61.29%

Table 4. Voltage Output Flyback Converter with Fuzzy Controller

$V_s$ (Volt)	SOC (%)	$V_{out}$ (Volt)
42	100,00	18.99
41	93,55	18.99
40	87,10	18.99
39	80,65	18.99
38	74,19	18.99
37	67,74	18.99
36	61,29	18.99

From Table 4, we can see the data simulation from fuzzy controller that generate the output of flyback converter at 18.99 V.

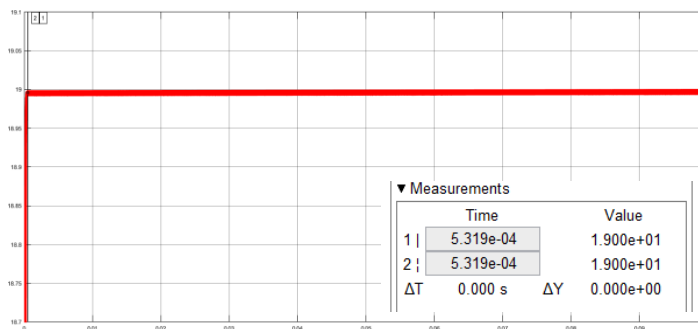

Figure 16. Output voltage waveform of ANFIS Controller

From Figure 16 red graphic is the flyback converter simulation controlled by ANFIS at SOC 100% and we can compare with the fuzzy control above.

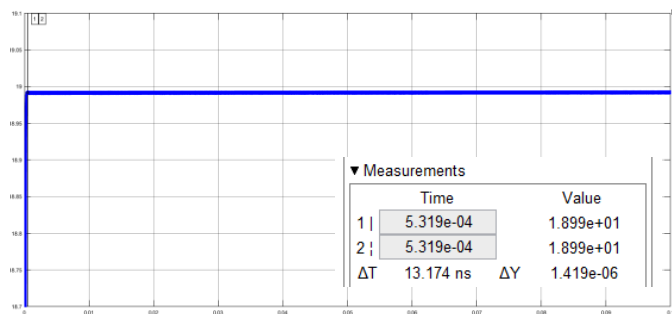

Figure 17. Output voltage waveform of Fuzzy Controller

From Figure 16 and Figure 17 we can see the performance form each controller, at the same time which is at  $5.31 \times 10^{-3}$  s anfis controller can reach output voltage 19 V, but the fuzzy controller still at 18.99 V

#### IV. Conclusion

Using ANFIS Method is representing to make the system can give a constant voltage for laptop batteries, in this paper we compare the performance between ANFIS controller and Fuzzy Logic Type – 1 to know difference performance and discuss controller more effective for the system. The converter output voltage produced by this simulation can reach set value at 19 V while SOC of batteries change regularly and the

performance between FUZZY -1 and ANFIS, ANFIS more faster to reach the setting point voltage output.

#### References

- [1] Ashraf A. Mohammed dan Samah M. Nafie, "Flyback Converter Design For Low Power Application", Sudanese Electricity Distribution Company, Khartoum, Sudan. IEEE 2015 International Conference on Computing, Control, Networking, Electronics and Embedded Systems Engineering (ICCNEEE). 2015.
- [2] K. Deepa, R. Jeyanthi, Shweta Mohan dan M. Vijaya Kumar, "Fuzzy Based Flyback Converter" Amrita School of Engineering, Amrita Vishwa Widyapeetham, Bangalore, India. IEEE 2014 International Conference on Advanced in Electrical Engineering (ICAEE). 2014.
- [3] Hidayat, Sasongko Pramonohadi, Sarjiya and Suharyanto, "A Comparative Study of PID, ANFIS and Hybrid PID-ANFIS Controllers for Speed Control of Brushless DC Motor Drive" Departemen Elektro Universitas Bung Hatta, Padang, Departemen Elektro dan Teknologi Informasi. IEEE 2013 International Conference on Computer, Control, Informatics and Its Applications. 2013.
- [4] Mehmet Can Taneri, Naci Genc, Ali Mamizadeh. "Analyzing and Comparing of Variable and Constant Switching Frequency Flyback DC- DC Converter" Van Yuzuncu Yil University Van, Turkey. IEEE 2019 The 4th International Conference on Power Electronics and their Applications (ICPEA). 2019.
- [5] Ashutosh Gupta, Kailash Rana, Dheeraj Joshi. "Design and Analysis of Multioutput Flyback Converter under Continuous and Discontinuous Conduction mode using PID Controller" Department of Electrical Engineering Delhi Technological University, Delhi. IEEE 2020 International Conference on Measurement, Instrumentation, Control and Automation (ICMICA). 2020.
- [6] Prasanna Kumar R, Ravishankar Deekshit, Rayees K.E, G. Bhoopendra, K. Singh, Vinod Chippakatti, "Flyback Topology Based Multi Output Pulsed Power Supply with Planar Magnetic Technology and Current Mode Control Method" Electrical and Electronics Departement B.M.S College of Engineering Bengaluru, India, Centrum Electronics Ltd Bengaluru India. IEEE 2017 International Conference on Smart grids, Power and Advanced Control Engineering (ICSPACE). 2017.
- [7] Shen Xu, Xinpeng Kou, Chong Wang, Qinsong Qian and Weifeng Sun. "New Digital Control Method For Improving Dynamic Response Of Synchronous Rectified Flyback Converter With CCM And DCM Mode" National ASIC System Engineering Research Center, Southeast University Nanjing, Jiangsu, 210096, PRChina. IEEE 2018 Applied Power Electronics Conference and Exposition (APEC). 2018.
- [8] Mukesh Kumar Bhaskar, Nidhi Singh Pal, Vinod Kumar Yadav. "A Comparative Performance Analysis of Automatic Generation Control of Multi-Area Power System Using PID, Fuzzy and ANFIS Controllers" Department of Electrical Engineering, Gautam Buddha University Greater Noida, India. Delhi Technological University, Delhi, India. IEEE 2018 International Conference on Power Electronics, Intelligent Control and Energy Systems (ICPEICES-2018). 2018.
- [9] I. M. Ginarsa. A. Soeprijanto, and M. H. Purnomo. "Controlling chaos using ANFIS-based Composite Controller (ANFIS-CC) in power systems." in International Conference on Instrumentation, Communication, Information Technology, and Biomedical Engineering 2009, Bandung, Indonesia, Nov. 2009
- [10] A. Bastian. "Influencing the nonlinearity at the transition between fuzzy logic rules," in Proceedings of 1995 IEEE International

- Conference on Fuzzy Systems. The International Joint Conference of the Fourth IEEE International Conference on Fuzzy Systems and The Second International Fuzzy Engineering Symposium, Yokohama, Japan, 1995.
- [11] F. Wahab, A. Sumardiono, A. R. Al Tahtawi, and A. F. A. Mulavari. "Desain dan Purwarupa Fuzzy Logic Control untuk Pengendalian Suhu Ruangan," (Fuzzy Logic Control Design and Prototype for Room Control), *J. Teknol. Rekayasa*, Vol. 2, No. 1, p. 1, Jul. 2017.
- [12] Irianto, Farid Dwi Murdianto, Epyk Sunarno, and Dewinta Dwi Proboningtyas, "Comparison Method of PI, PID and Fuzzy Logic Controller to Maintain Speed Stability in Single Phase Induction Motor," in 2021 INTEK Jurnal Penelitian, 2021.
- [13] Ainur Rofiq Nansur., Alfis Syah Laili Hermawan., & Farid Dwi Murdianto "Constant Voltage Control Using Fuzzy Logic Controller (FLC) to Overcome the Unstable Output Voltage of MPPT in DC Microgrid System," in 2018 International Electronics Symposium on Engineering Technology and Applications IES-ETA, 2018.
- [14] Neily Itsqiyah Mufa'ary, Indhana Sudiharto, and Farid Dwi Murdianto, "Comparison of FLC and ANFIS Methods to keep Constant Power Based on Zeta Converter," in 2021 INTEK Jurnal Penelitian, 2021.
- [15] R P Anggraini, M Z Efendi, and F D Murdianto "Modeling And Simulation Of Miso-Buck Converter Using Anfis On Dc Microgrid Dstribution System," in IOP Conference Series: Materials Science and Engineering ICIMECE. 2020.
- [16] P Jagtap, G. N. Pillai, "Comparison of Extreme—ANFIS and ANFIS Networks for Regression Problems" in International Advance Computing Conference. 2014.